

# CLAMPBRO®

# CONTRACTOR®



## AIR FRAME NAILER

MODEL NO: CFN34

PART NO: 3110397

## OPERATION & MAINTENANCE INSTRUCTIONS

UK  
CA | CE

ORIGINAL INSTRUCTIONS

DL1122 - REV 3

---

## INTRODUCTION

---

Thank you for purchasing this CLARKE product.

Before attempting to use this product, please read this manual thoroughly and follow the instructions carefully. In doing so you will ensure the safety of yourself and that of others around you, and you can look forward to your purchase giving you long and satisfactory service.

---

## SPECIFICATION

---

Model No	CFN34
Dimensions	500 x 120 x 378 mm
Weight	4 kg
Drive Speed	60 (shots/min)
Nail size	50-90 mm
Magazine capacity	80
Compressed Air consumption	14.8 cfm
Maximum Allowable Pressure	120 psi /8.3 bar
Recommended Allowable Pressure Range	80 - 110 psi /5.51 - 7.58 bar
Sound Power Measured LwA	112.5 dBLwA

---

## GUARANTEE

---

This product is guaranteed against faulty manufacture for a period of 12 months from the date of purchase. Please keep your receipt which will be required as proof of purchase.

This guarantee is invalid if the product is found to have been abused or tampered with in any way, or not used for the purpose for which it was intended.

Faulty goods should be returned to their place of purchase, no product can be returned to us without prior permission.

This guarantee does not effect your statutory rights.

---

# SAFETY WARNINGS

---

## SAFETY OF THE NAIL GUN

1. Check prior to use that the safety and triggering mechanism is functioning properly and that all nuts and bolts are tight.
2. **DO NOT** carry out any modifications to the nail gun.
3. **DO NOT** disassemble or make inoperative any parts of the nail gun such as the safety yoke.
4. **DO NOT** perform any "emergency repairs".
5. The nail gun should be serviced properly and at regular intervals in accordance with the instructions.
6. **AVOID** weakening or damaging the nail gun, for example by:
  - punching or engraving;
  - modification not authorised by the manufacturer;
  - guiding against templates made of hard material such as steel;
  - dropping or pushing across the floor;
  - using the equipment as a hammer;
  - applying excessive force of any kind.

## SAFETY AT WORK

1. **NEVER** point any operational staple/nail gun at yourself, any other person or animals.
2. Hold the staple/nail gun during the work operation in such a way that no injuries can be caused to the head or to the body in the event of a possible recoil.
3. **NEVER** actuate the staple/nail gun into free space. This will avoid any hazard caused by free flying fasteners and excessive strain on the tool.
4. The nail gun shall be disconnected from the compressed air system during transportation, especially where an unusual physical posture is adopted whilst moving.
5. Carry the staple/nail gun at the workplace using only the handle, and never with the trigger actuated.
6. Take conditions at the workplace into account. Fasteners can penetrate thin workpieces or slip off corners and edges of workpieces and thus put people at risk.
7. For personal safety, use protective equipment such as hearing and eye protection and safety gloves.

# CONNECTION TO THE COMPRESSED AIR SYSTEM



**WARNING: COMPRESSED AIR CAN BE DANGEROUS. ENSURE THAT YOU ARE THOROUGHLY FAMILIAR WITH ALL PRECAUTIONS RELATING TO THE USE OF COMPRESSED AIR AND COMPRESSED AIR SUPPLIES.**

1. Ensure that the pressure supplied by the compressed air system does not exceed the maximum allowable pressure of the nail gun.
2. Make sure that the safety yoke is not depressed.
3. Connect the nail gun to the compressed air supply using suitable hose equipped with quick-action connectors.
4. Check for proper functioning by applying the muzzle of the nail gun to a piece of wood and actuating the trigger once or twice.

## RECOMMENDED TYPICAL CONFIGURATION

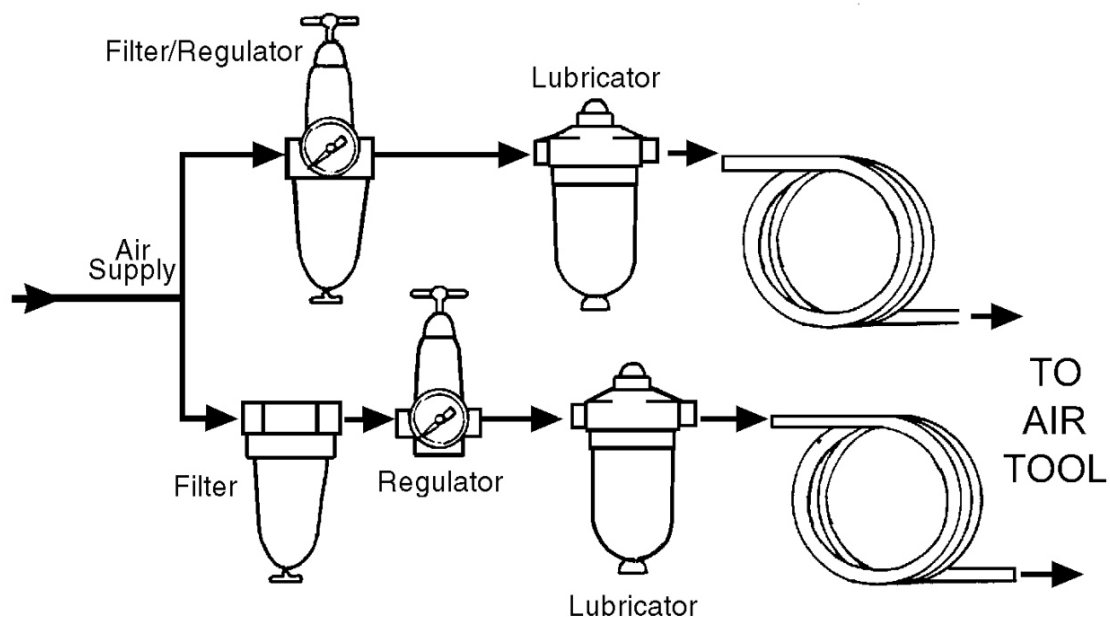

---

## PRODUCT OVERVIEW

---

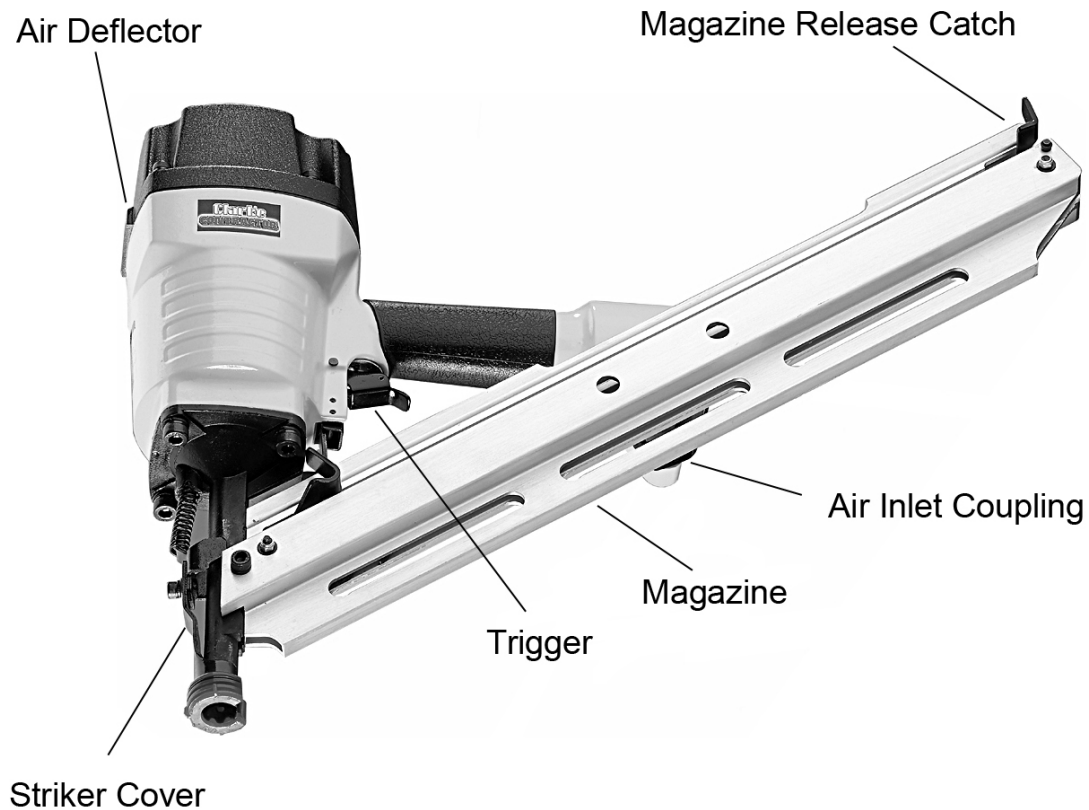

The CFN34 is supplied with:-

- Oil Bottle
- 4 x Hex Keys (3,4, 5 & 6 mm)
- Moulded Carry Case

Contact your CLARKE dealer immediately if any parts are missing or damaged.

---

## PREPARATION FOR USE

---

1. Screw the quick fit air intake coupling to the nailer as shown on the right.

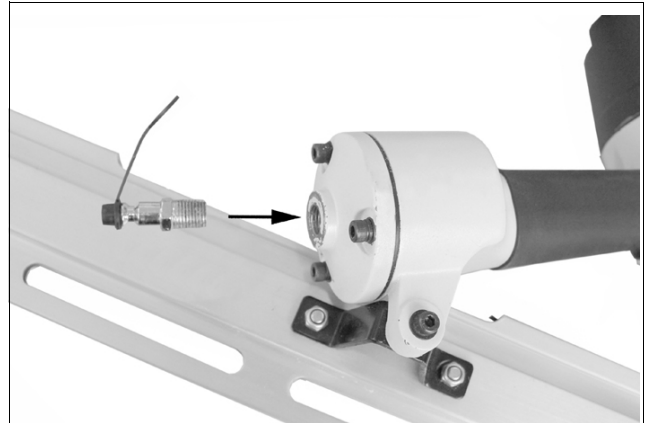

**WARNING: ALWAYS CHECK THE SAFETY MECHANISM BEFORE USING THE NAILER. TO DO THIS, CARRY OUT THE SAFETY CHECKS IN THE PROCEDURE DETAILED BELOW. WHEN USING THE NAIL GUN ALWAYS WEAR EYE PROTECTION.**

---

### PRELIMINARY CHECKS

Make sure that the air supply is not connected to the nailer. **DO NOT** put any nails in the air nail gun until directed to do so in the following procedure.

It is essential that the air nail gun is lubricated before each use.

1. Use the CLARKE airline oil provided with your nailer to lubricate the safety yoke and trigger mechanism. **DO NOT** use detergent oils or any oil that contains artificial additives these may cause the nail gun to malfunction.
2. Place 2 or 3 drops of oil in to the air intake twice a day when the nailer is being used.
3. Check all of the nailers screws for tightness.

### CONNECTING THE AIR SUPPLY TO THE NAILER

Ensure you are wearing eye protection before connecting the air supply.

1. Push the hose from the compressor on to the nailer. The collar on the hose connector will slide forward and click in place.
2. Refer to the air compressor instruction book for the starting procedures of the compressor. Set the compressor output to 5.5 Bar (80 psi).
  - Check that the nailer does not leak air.

### CHECKING THE SAFETY MECHANISM

1. Hold the nailer in mid-air pointing downwards and pull the trigger.

- The nailer should not operate. If it does the safety mechanism is faulty. **DO NOT** use the nailer. Return it for repair to the place of purchase.
2. Release the trigger and with your finger off the trigger, press the safety yoke against a scrap piece of timber.
    - The nailer should not operate. If it does, the safety mechanism is faulty. Do not use the nailer. Return it for repair to the place of purchase.

## **CHECKING OPERATION OF THE NAILER**

1. Press the safety yoke against a piece of scrap timber and pull the trigger. The nailer should operate. If it does not return it for repair to the place of purchase.
2. With the air nail gun off the work piece, pull the trigger and then press the safety yoke against the workpiece.
  - The nail gun should **NOT** operate. If it does return for repair to the place of purchase.

## LOADING NAILS

Always disconnect the nailer from the air supply before loading nails.

1. Pull the nail pusher back as far as possible until the catch clicks into place.

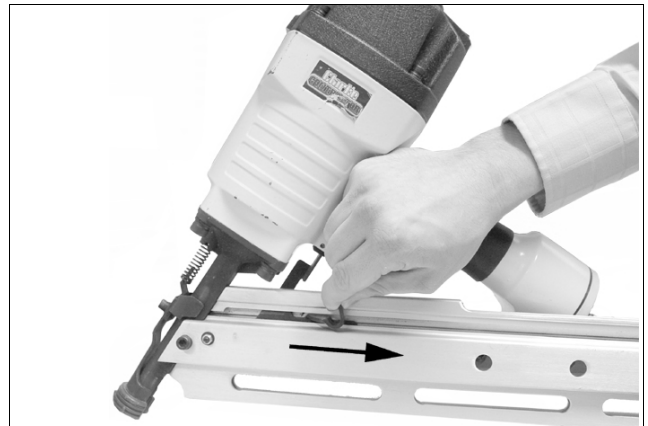

2. Slide the nails through the loading slot into the magazine as shown.

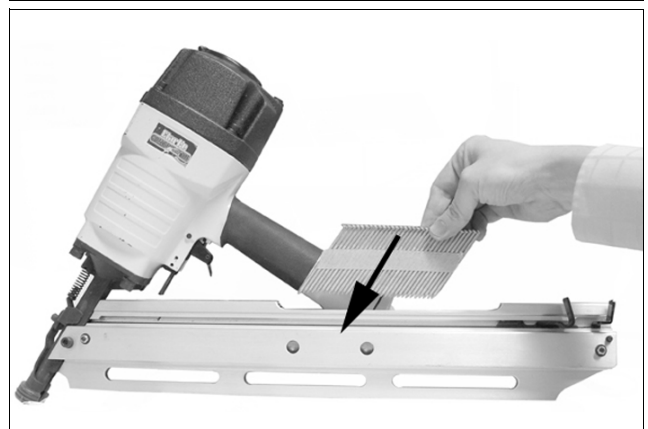

3. Press the release latch on the rear of the magazine and slide the nail pusher forward.

Your nailer is now ready to use.

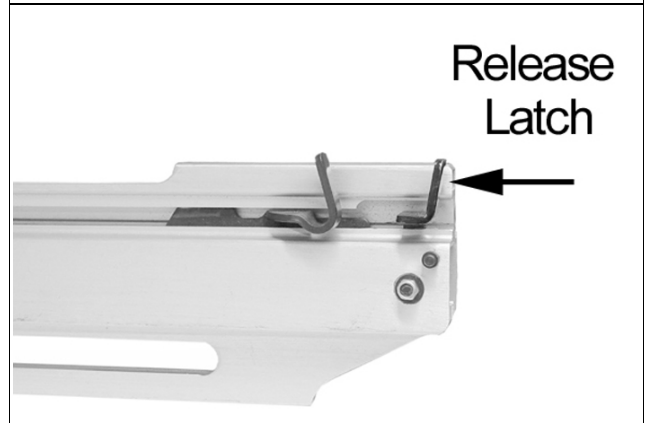



---

## OPERATION

---

1. Turn ON the air supply and check for air leaks. If any are apparent, rectify before proceeding.
2. Ensure the operating pressure is set to between 5.51 - 7.58 bar (80 - 110 psi), depending upon the size of nail used and type of material being worked.
  - Harder material or bigger nails will mean a higher pressure is required
3. Hold the nailer firmly with the safety yoke flat against the workpiece and at 90° to it.
4. Squeeze the trigger to drive the nail.
5. Each squeeze of the trigger will drive one nail only.
  - If the nail is driven in too deep, reduce the air pressure in increments of 0.5 bar (7 psi), checking the result after each adjustment. You should aim, to work with the lowest possible air pressure. This will save energy, produce less noise and reduce tool wear.
  - If the nail is not driven in sufficiently, increase the air pressure in increments of 0.5 bar (7 psi), checking the result after each adjustment.



**WARNING: DO NOT EXCEED THE MAXIMUM OPERATING PRESSURE OF THE TOOL; 8.27 BAR (120 PSI).**

---

Avoid triggering the nailer when the nail magazine is empty. If the nailer operates improperly or is defective, disconnect from the air supply and have the tool inspected by a qualified service technician.

In the event of long breaks in work or at the end of the working session, disconnect the tool from the air supply and empty the nail magazine.

The air connector of the nailer and the hose should be protected against contamination. The ingress of coarse dust, chippings, sand etc will result in leaks and damage to the nailer and the couplings.

## DISCONNECTING THE AIR SUPPLY

---



**WARNING: NEVER DISCONNECT THE AIR SUPPLY HOSE UNTIL THE COMPRESSOR HAS BEEN SHUT DOWN AND THE COMPRESSED AIR RELEASE.**

---

1. Refer to the compressor instruction book for the procedures to shut down and release the compressed air.

2. Once the pressure has been released, disconnect the air supply hose from the nail gun. Slide the collar on the hose connector away from the nailer. The hose will release and spring backwards.
3. Remove any nails remaining in the magazine of the nailer.
4. Store the nailer safely in its box in a dry, secure environment.

## CLEARING A JAM

To clear a jammed nail proceed as follows:

1. Follow the compressor procedure to switch off and release the air pressure.
2. Disconnect the air supply hose.
3. Pull the nail pusher back as far as possible until the catch clicks into place.
4. Remove the nails from the magazine.
  - The jammed nail should then release. If the jammed nail does not release, proceed as follows.
5. Remove the bolt indicated using the hexagonal key supplied.
6. Remove the striker cover.
7. Remove the jammed nail using pliers or similar tool.
8. Replace the striker cover.

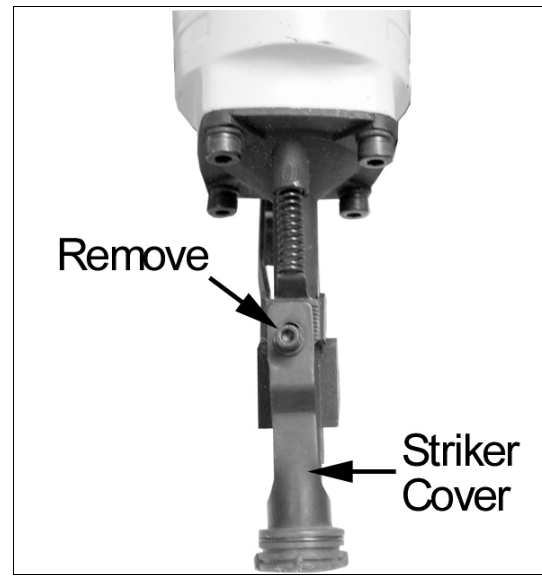

---

## MAINTENANCE

---



**WARNING: DISCONNECT THE NAIL GUN FROM THE COMPRESSED AIR SUPPLY AND EMPTY THE MAGAZINE BEFORE PREFORMING ANY MAINTENANCE.**

---

## LUBRICATION

To lubricate the internal components during operation, an air line lubricator should be used.

If an air system oiler is not being used, lubricate the nail gun every 2 hours with a few drops of air line oil, dripped into the air inlet.

Clarke Airline Oil is available from your CLARKE dealer part no. 3050825.

- Only use the oil provided to lubricate the nail gun.

- Lubricate the moving parts of the safety yoke and trigger mechanism before using the nailer.
- Do not use detergent oils or any oil that contains artificial additives as these may cause the nailer to malfunction.
- Place 2 or 3 drops of lubricating oil into the air intake hose connection point twice a day when the nailer is being used. A bottle of CLARKE Air Line Oil\*\* is supplied with the tool.

## **CLEANING**

1. Keep the body of the nailer clean and free from debris.
2. Make sure that the magazine release lever and the trigger are kept clean and in good working order.
3. Clean the magazine and nail pusher by blowing with compressed air.
4. Check and clean, if necessary, the air inlet gauze filter.
5. Periodically drain water from compressor air tank and air line.

## **SERVICE AND REPAIR**

All repairs must be carried out by a qualified service technician.

## **STORAGE**

When not in use, disconnect from air supply, clean the nail gun and store in a safe, dry, childproof location.

## **MAINTENANCE CONSIDERATIONS**

Be aware that factors other than the tool may effect its operation and efficiency such as reduced compressor output, excessive demand on the airline, moisture or restrictions in the line, or the use of connectors of improper size or poor condition which will reduce air supply.

Grit or gum deposits in the tool may also reduce efficiency. This condition can be corrected by cleaning the air strainer and flushing out the tool with gum solvent oil, or failing this, the tool should be disassembled, thoroughly cleaned, dried and reassembled.

If the tool runs erratically or becomes inefficient, and the air supply is sound, dismantle the piston assembly and replace worn or damaged parts, or take the tool to your CLARKE dealer.

The use of parts other than CLARKE replacement parts may result in safety hazards, decreased tool performance and will invalidate your warranty.

# DECLARATION OF CONFORMITY



Hemnell Street, Epping, Essex CM16 4LG

## DECLARATION OF CONFORMITY

This is an important document and should be retained.

We hereby declare that this product(s) complies with the following statutory requirement(s):

*Supply of Machinery (Safety) Regulations 2008*

The following standards have been applied to the product(s):

EN/ISO 11148-13:2018

The technical documentation required to demonstrate that the product(s) meet(s) the requirement(s) of the aforementioned legislation has been compiled and is available for inspection by the relevant enforcement authorities.

The UKCA mark was first applied in: 2022

**Product Description:** 34 Degree Clipped Head Air Frame Nailier  
**Model number(s):** CFN34  
**Serial / batch Number:** N/A  
**Date of issue:** 06/10/2022

Signed:

J.A. Clarke  
Director



Fitzwilliam Hall, Fitzwilliam Place, Dublin 2

## DECLARATION OF CONFORMITY

This is an important document and should be retained.

We hereby declare that this product(s) complies with the following directive(s):

2006/42/EC *Machinery Directive*

The following standards have been applied to the product(s):

EN/ISO 11148-13:2018

The technical documentation required to demonstrate that the product(s) meet(s) the requirement(s) of the aforementioned directive(s) has been compiled and is available for inspection by the relevant enforcement authorities.

The CE mark was first applied in: 2007

**Product Description:** 34 Degree Clipped Head Air Frame Nailier  
**Model number(s):** CFN34  
**Serial / batch Number:** N/A  
**Date of issue:** 06/10/2022

Signed:

J.A. Clarke  
Director

# EXPLODED DIAGRAM

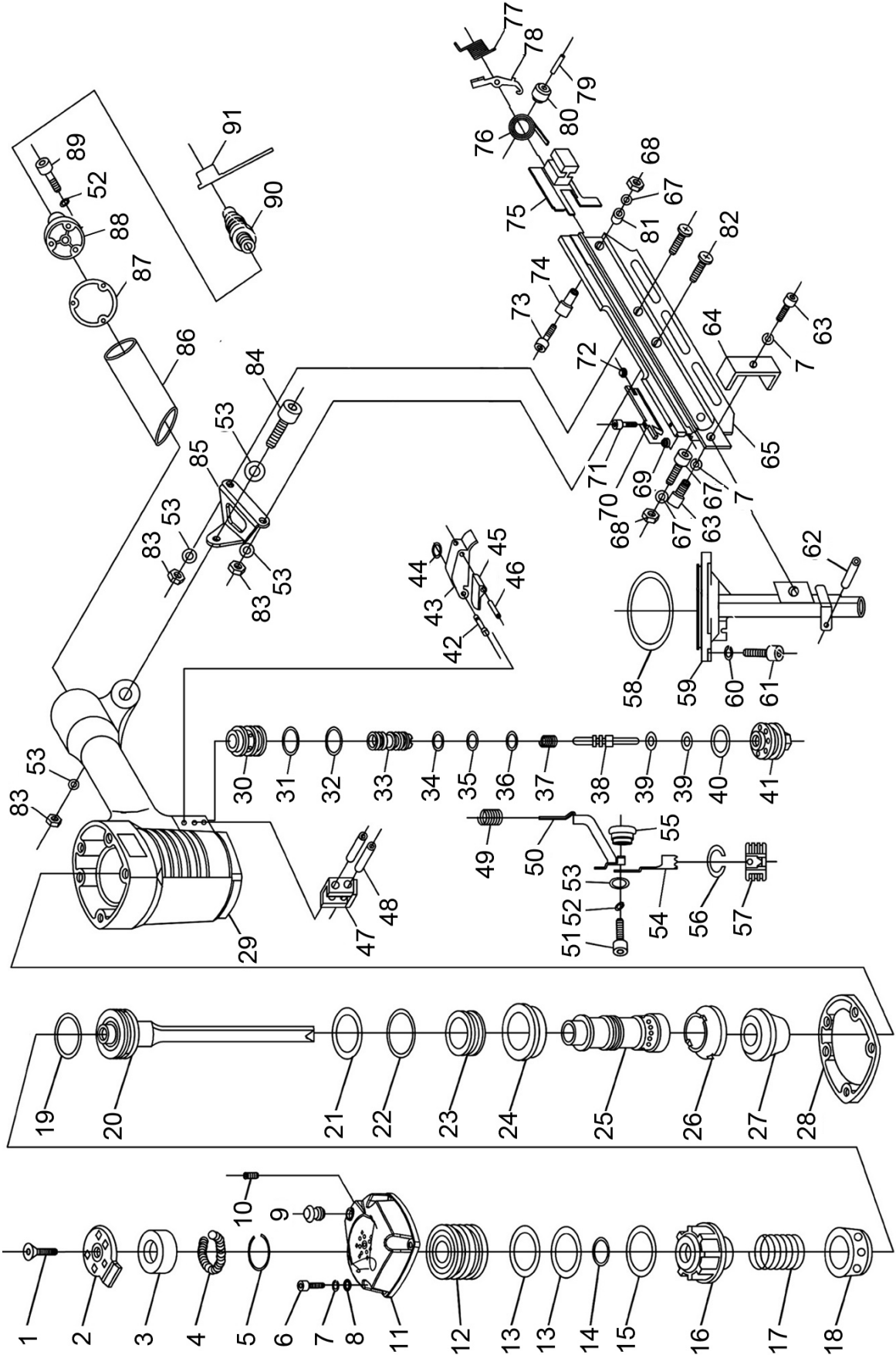

## SPARE PARTS LIST

No	Description
1	Bolt M8 x 30
2	Air deflector
3	Deflector rubber
4	Spring
5	Spring wire
6	Bolt M6 x 30
7	Spring washer
8	Flat washer
9	Cylinder core
10	Bolt M5 x 5
11	Cylinder cover
12	O-ring 41.7 x 3
13	O-ring 56 x 3.1
14	Head valve piston
15	Spring seat
16	Compression spring
17	Spring washer collar
18	Collar
19	O-ring 42.3x5
20	Main piston
21	O-ring 57.5 x 3
22	O-ring 88 x 3
23	Fixed ring
24	Sealing ring
25	Cylinder
26	Bumper
27	Cylinder washer
28	Gun body
29	Rubber washer
30	Trigger valve seat
31	O-ring 15 x 2.65
32	O-ring 17 x 1.5
33	Trigger guide valve

No	Description
34	O-ring 6.1 x 1.8
35	O-ring 6.4 x 2
36	O-ring 9 x 1.8
37	Switch spring
38	Switch pipe
39	O-ring 2.5 x 1.5
40	O-ring 20.3 x 2.3
41	Switch seat
42	Trigger pin
43	Trigger
44	O-ring 1.7 x 2
45	Safety spacer
46	3x16
47	Safety guide
48	Pin 3 x 25
49	Compression spring
50	Bolt M5 x 8
51	Flat washer
52	Spring washer
53	Adjusting nut
54	Safety yoke
55	Safety nose
56	Collar collar
57	Safety nose collar
58	O-ring 59 x 1.8
59	Driver guide
60	Spring washer
61	Bolt M8 x 25
62	Bolt M6 x12
63	Magazine
64	Drive nail bar
65	Bolt M4 x 8
66	Nut M4

67	Flat washer
68	Bolt M4 x 40
69	Safety pipe
70	Safety pipe case
71	Pin case
72	Spring pin
73	Bolt M6 x 12
74	Pusher
75	Spring pin 3 x 20
76	Spring pin 3 x 20
77	Bolt M3 x 14
78	Nut M3
79	Pin B4 x 30
80	Spring
81	Spring core

82	Pin B5 x 12
83	Release latch
84	Block
85	Spring
86	Bolt M5 x 25
87	Fixed seat
88	Nut M6
89	Nut M5
90	Rubber handle case
91	End cap washer
92	End cap
93	Flat washer
94	Bolt M5 x 20
95	Air plug
96	Air plug case

---

## CONSUMABLES

---

The following consumables are available from your local Clarke dealer.

NAILS - PACK of 200	
Length	Part No:
50mm	18004144
63mm	18004145
75mm	18004246
90mm	18004247

# A SELECTION FROM THE VAST RANGE OF

# Clarke®

## QUALITY PRODUCTS



**AIR COMPRESSORS**  
From DIY to industrial, Plus air tools, spray guns and accessories.

**GENERATORS**  
Prime duty or emergency standby for business, home and leisure.

**POWER WASHERS**  
Hot and cold, electric and engine driven - we have what you need

### WELDERS

Mig, Arc, Tig and Spot.  
From DIY to auto/industrial.

**METALWORKING**  
Drills, grinders and saws for DIY and professional use.

**WOODWORKING**  
Saws, sanders, lathes, mortisers and dust extraction.

**HYDRAULICS**  
Cranes, body repair kits, transmission jacks for all types of workshop use.

**WATER PUMPS**  
Submersible, electric and engine driven for DIY, agriculture and industry.

**POWERTOOLS**  
Angle grinders, cordless drill sets, saws and sanders.

**STARTERS/CHARGERS**  
All sizes for car and commercial use.



## PARTS & SERVICE: 0208 988 7400

**Parts Enquiries**  
[Parts@clarkeinternational.com](mailto:Parts@clarkeinternational.com)

**Servicing & Technical Enquiries**  
[Service@clarkeinternational.com](mailto:Service@clarkeinternational.com)

SALES: UK 01992 565333 or Export 00 44 (0)1992 565335

**Clarke® INTERNATIONAL** Hemnall Street, Epping, Essex CM16 4LG  
[www.clarkeinternational.com](http://www.clarkeinternational.com)